



**VIEWPOINT
SYSTEMS**

Designed to be Right. Engineered to Work.

Rochester: 800 West Metro Parkway • Rochester, NY 14623 •
Phone (585) 475-9555 • Fax (585) 475-9645 •
Boston: 126A Main Street • Watertown, MA 02472 •
Phone (617)926-9064 • Fax (617)924-3402 •

Services: Viewpoint Systems is a highly experienced systems integrator dedicated to delivering high-caliber, custom solutions in manufacturing test, process monitoring, product development, industrial automation, and project management.

Products: Viewpoint has developed add-on products for LabVIEW to make your job easier:
MultiCom: Access up to 64 serial ports from LabVIEW for Windows
ViewPort: LCD & VFD Displays for LabVIEW Real-Time Systems
PCI-DIO64: PCI Version 64 channel intelligent high-speed digital I/O
PXI-DIO64: PXI Version 64 channel intelligent high-speed digital I/O
Peek/Poke: Memory and I/O access from LabVIEW
Opto32-128: Low Input Current SCXI opto-isolated digital input board
DIO-128: 128 channel high speed digital I/O
6K VI Motion Library: Active X Library for Compumotor's 6K Con-

troller

Viewpoint Systems is a National Instruments Select Integrator and Certified Training Center and a Registered Gold Tier Member of CSIA.



800 West Metro Parkway
Rochester, NY 14623
ph: (585) 475-9555
fax: (585) 475-9645
www.ViewpointUSA.com

**VIEWPOINT
SYSTEMS**



Viewpoint News

www.ViewpointUSA.com

Winter 2004

Bio-Reactor Monitoring and Control System SCADA System

Client

Major Pharmaceutical Company

Technical Highlights

- OPC Client for PLC communication
- National Instruments' Remote Panel Technology for off-site configuration and viewing
- Microsoft Access database
- Viewpoint's Component Engine for a flexible data acquisition system
- Diverse data acquisition devices: DAQ, RS-232, PLC (OPC)
- Common driver model: drop in drivers, self-aware configuration
- Flexible GUIs with drop in screens
- Easy Configuration via MS Excel
- E-mail and page alarm conditions

Background

The researchers at a pharmaceutical company were inefficient because they were spending too much time tending to their experiments. Checking the oxygen, carbon monoxide, nitrogen, temperature, and other parameters every few hours to insure progression of the experiment was a manual process. They needed to upgrade their system to a fully automated preventative monitoring system. The purpose of this system is to routinely monitor and alert the scientists in advance of a failure, reducing waste and freeing them for more valuable design and

Continued on page 2

Viewpoint In The News!



Viewpoint Systems has been named a Top 100 Company in Rochester, New York, placing # 54 on this prestigious list. The Rochester Top 100 recognizes the

accomplishments of privately-owned companies and is a list of the fastest growing companies in Rochester. The criteria used in selecting companies is based on revenue growth in the past three years, calculating both dollar and percentage growth.

“This honor is especially meaningful given the sluggish economy in the last few years. Viewpoint's strength lies in the breadth and

LabVIEW™ Certifications

We would like to recognize several individuals who have recently earned National Instrument accreditations.

Certified LabVIEW Architect

Douglas Femec

Certified LabVIEW Developers

Daniel Blasdell
Benjamin Hysell

Certified Professional Instructor

Kyle Hall
Brian Lander
John Shannon

A complete listing of Certified Developers, Certified LV Architects and Certified Professional Instructors

Classes are filling up! Register at www.ni.com/custed or call (585) 475-9555. See page 3 for schedule.

Continued from page 1

analysis tasks.

Challenge

Viewpoint needed to create an extensible system capable of monitoring numerous signals interfaced to multiple bioreactors. Parameters such as temperature, fluid level, O2, dissolved oxygen, pH, and CO2 are collected and totalized from the bio-reactors. Control of pH and Nitrogen levels are configured and set by the PC. Since the experiments run over many days, even weeks, the alarm system must be capable of paging or e-mailing the scientists when a parameter is out of range. The configuration of this system and viewing of data needed to be available from any of a number of computers connected to the network. Also, the data needed to be available for additional processing on other connected networks.

This system was designed so that existing equipment could be used while keeping future improvements in mind. Current test cells use

existing PLCs and DAQ cards for data acquisition. Future test cells will take advantage of Compact Fieldpoint flexibility for greater process control.

Viewpoint's Solution

There are three important software components to this application: PLC communication via OPC, Viewpoint's Component Engine which offers ease of configuration, acquisition, and control, and a flexible alarm engine for page and e-mail notification.

This system utilizes RS-232 to Ethernet converters and an OPC client to acquire signals from the bioreactors and log the data to an Access database. The data is then processed, checked for alarm conditions, and viewed. National Instruments' Remote Panel viewing and control technology facilitates off-site monitoring.

Results

The remote monitoring allows the researchers to view the progress of the experiments in their offices, or even at home. The preventative alarm monitoring and

early notification has allowed the company to save

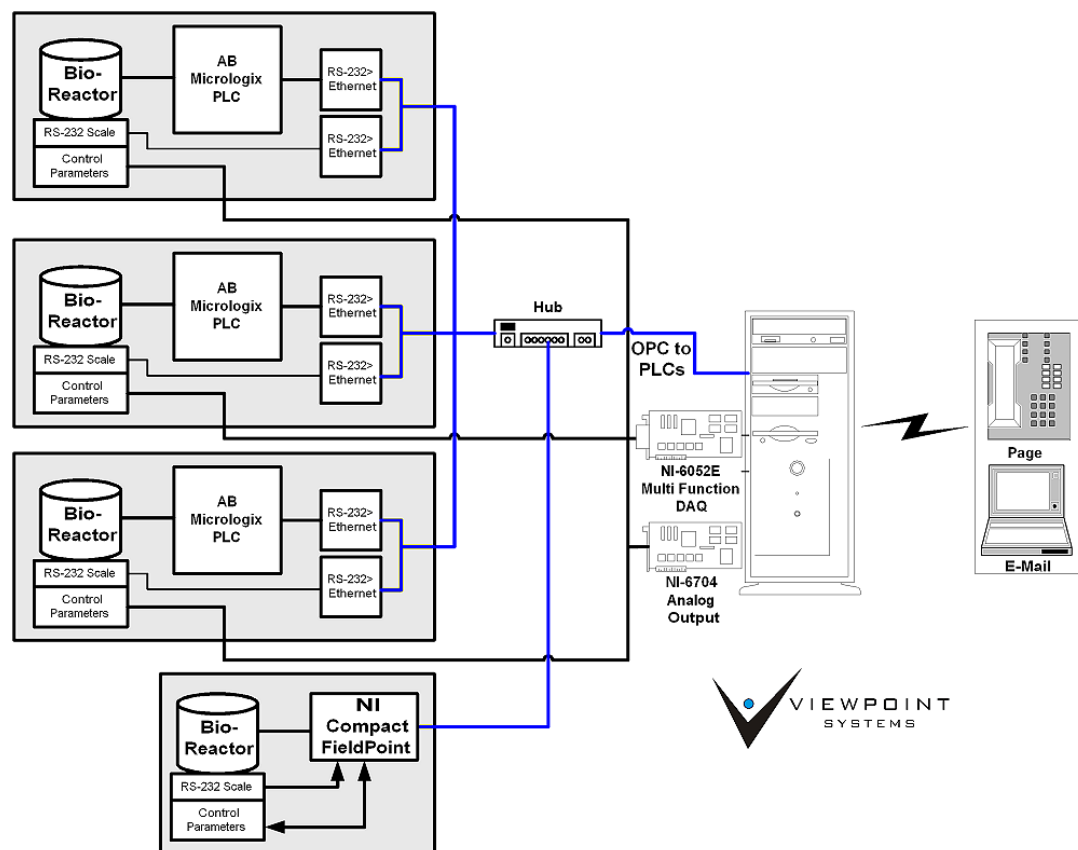

Bio-Reactor SCADA Overview

National Instruments Training

All classes listed below are held at Viewpoint's Certified Training Center in Rochester.

To register go to www.ni.com/training or call (585) 475-9555.

For detailed course descriptions, prerequisites & complete schedule go to www.ViewpointUSA.com/training

LabVIEW Basics I: Introduction

2/2, 3/8, 4/19, 5/17 3 days

Covers the fundamentals of LabVIEW programming and constructing simple VIs, building applications involving data acquisition, analysis, and user interface.

\$1495

LabVIEW Basics II: Development

4/22, 5/20 2 days

Builds on the Basics I and take full advantage of clusters, globals, locals, attribute nodes and more. Learn techniques to reduce memory requirements, optimize execution speed and build high performance VIs.**

\$995*

LabVIEW Intermediate I: Design Patterns

3/29 3 days

Teaches you structured practices to design, develop, test, and deploy LabVIEW applications. Analyze your application requirements, choose the correct design pattern and data structures for your application, and quickly test your design.**

\$1495

LabVIEW Intermediate II: Architecture

4/1 2 days

Teaches you memory management and performance-enhancing techniques to maximize application performance. Extend application functionality by leveraging other applications using DLLs, Active X and the Internet.**

\$995*

LabVIEW Advanced Application Development

4/5 4 days

Teaches you to develop complex applications with greater productivity, better code quality, and lower cost. Learn about software reuse, coding techniques and architectures and object-oriented concepts. The course includes a final application.**

\$2495

LabVIEW Data Acquisition and Signal Conditioning

2/16 3 days

Teaches fundamental data acquisition concepts. Learn how to install and configure data acquisition software and hardware.**

\$1495

TestStand 1: Introduction

3/15 3 days

Use features provided in the TestStand environment and learn the basics of customizing. Upon completion, develop test applications using built-in tools supplied with TestStand.**

\$1795

TestStand II: Customization

3/18 2 days

Customize the functionality built in to TestStand. Multithreading and multi-UUT testing, advanced reporting techniques, and application program interface (API). Concludes with system design projects.**

\$1195*

LabVIEW Real Time Using FieldPoint

3/3 3 days

Introductory hands-on course that teaches LabVIEW Real-Time using a FieldPoint-20xx controller. Develop and deploy real time applications for distributed measurement and control functionality.**

\$1495

LabVIEW Machine Vision & Image Processing

5/3 2 days

Learn the fundamentals of machine vision, and locating cameras, lenses, and lighting equipment. Use vision software and hardware to calibrate coordinates and acquire and quantify images.**

\$1195

Motion Control Fundamentals

5/27 2 days

Learn how to configure a motion acquisition system, develop basic motion trajectories, and create feedback control loops. Identify types of moves and create motion control solutions.**

\$995



* 25% discount if scheduled concurrently with Course 1

**Indicates prerequisite required.